



There when you need us most

VN Series

Non-Clog Wastewater Pump

Installation & Operating Manual



Congratulations on Your Choice in Purchasing this Webtrol Pump!

Its Quality is unsurpassed in material and workmanship and has been factory tested.
If properly installed, it will give many years of trouble free service.

Table Of Contents

Introduction2
Specifications2
Installation2
Electrical3
Operation3
Disassembly of pump4
Maintenance4
Troubleshooting5
Owner information6

Introduction

This manual was prepared to assist the installer and/or operator in understanding the proper method of installing, operating and maintaining the VN Non-Clog pump. We recommend that you thoroughly understand the proper installation and start-up procedures, prior to starting the pump.

Check the following upon receipt of your pump:

- 1) Is the pump exactly what you ordered? **Check nameplate.**
- 2) Has and damage occurred during shipment? Are any bolts or nuts loose?
- 3) Have all necessary accessories been supplied?

We recommend that you keep a spare pump on hand in case of emergencies. Keep this instruction manual in a place for future reference.

Specifications

Check the nameplate for your pumps's head (HEAD), discharge volume (CAPACITY), speed (SPEED), motor voltage and current. Other specifications are noted in the chart.

Specifications						
Model	HP	Volt	AMP	Ph	Dimensions (L X W X H)	Weight
VN50C49	5	230	12.0	3	25.7"x15.8"x32.5"	265 Lbs.
VN50D49	5	460	6.0	3	25.7"x15.8"x32.5"	265 Lbs.
VN75C62	7.5	230	18.0	3	25.7"x15.8"x32.5"	267 Lbs.
VN75D62	7.5	460	9.0	3	25.7"x15.8"x32.5"	267 Lbs.
VN100C76	10	230	23.0	3	25.7"x15.8"x32.5"	276 Lbs.
VN100D76	10	460	11.5	3	25.7"x15.8"x32.5"	276 Lbs.

Installation

Sewage pumps must be installed in a tank or basin that is vented in accordance with local plumbing codes. Installation should be at sufficient depth to ensure that all plumbing is below frost line. Installation and piping instruction are included with control panel, rail system and basin instructions. If pump is being retrofitted to an existing rail system, accessory parts may be required. Consult the factory and advise make and model of rail system being used.

- 1) **Warning:** *Under no circumstances should cable be pulled while the pump is being transported or installed. Attach a chain or rope to the grip and install the pump.*
- 2) This pump must not be installed on its side or operated in a dry condition. Ensure that it is installed upright on a secure base or rail.
- 3) *If pump is to operate with floats. Make sure that float switches swings freely, minimum 1" clearance is recommended.*
- 4) Install piping so that air will not be entrapped. If piping must be installed in such a way that air pocket are unavoidable, install an air release valve wherever such air pockets are most likely to develop.
- 5) Do not permit end of discharge piping to be submerged, as backflow will result when the pump is shut down.
- 6) Install a full flow ball check valve as close to the discharge outlet on the pump as possible.
- 7) *To avoid dry operation, install an automatic operating system, similar to typical installation in Fig 1.*

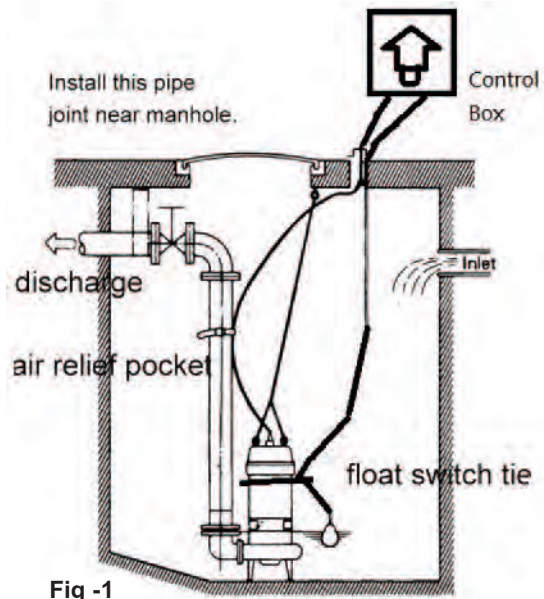

Fig -1

Electrical

Caution

- 1) Check your local electrical and plumbing codes to ensure you comply with regulations. These codes have been design with your safety in mind . Be sure to comply with them.
- 2) We recommend that separate circuit be run from electrical distributing panel that is properly protected with a fuse or circuit breaker. Consult local electrician for wiring.
- 3) Never make adjustment or repairs to any electrical pumps / products with power connected.

Seal Leak Detector

The Seal Leak Detector Cord is a two-wire circuit which detects the presence of water in the oil filled cavity of a double seal system. The control panel must have a Seal Leak Detector circuit to utilize this feature.

When moisture is detected in the seal cavity an alarm is activated in the panel. Depending on the panel, either one or two terminals will be marked for this circuit. If there are two terminals, then the two conductors in the cord will be placed on those terminals. If only one terminal is present, the black conductor will go to that terminal and the other to the panel ground lug. Depending on the panel manufacturer and schematic, the alarm light may activate when powered up. If this happens reverse the conductors so that the green wire is on the grounded terminal. The alarm should deactivate.

If the panel does not have a seal leak circuit, the conductors may be terminated at the panel and a service tech can check the seals occasionally by connecting an ohm meter to the black and green wire. As the moisture in the seal cavity increases, the ohm readings will decrease towards 0 ohms indicating a seal leak.

Supply Voltage

- 1) Ensure that the electrical power supplying panel is "OFF".
- 2) Ensure that pump (double) and alarm (single) circuit breakers in the panel are in "OFF" position.
- 3) Turn on power "ON" to the panel from the building service panel.
- 4) Using test (volt) meter verify that the incoming panel voltage is within 10% of pump nameplate voltage (for 230V pump, voltage at he panel must be 207V - 253V and 414V-506V for 460V pump) If the voltage is outside this range, do not continue with station start-up. The voltage problem must be corrected prior to proceeding.

Cable

- 1) **Warning:** Never let the end of the cable contact water.
- 2) If the cable is lengthened, do not immerse the splice in water.
- 3) Fasten the cable to the discharge piping with tape or vinyl strips.
- 4) Install the cable so that it will not overheat. Overheating can be caused by coiling the cable or exposing it to direct sunlight.

Operation

Warning: Sewage pump can develop dangerous and harmful fumes. Make note that fumes developed by sewage are very dangerous to our health and even fatal.

- 1) The VN non-clog submersible sewage pump has a semi-closed impeller design and ranges from 5-10 HP - 230V, 460V 3Phase voltage.
- 2) Turn the operating switch on and off a couple of times to check for normal pump start. Make sure to check the pump rotation. If discharge volume is low and unusual sounds are heard when pump is operating, rotation should be reversed. When this happens reverse two out of the three motor leads.
- 3) Run water into pit/basin until motor is covered.
- 4) Make sure discharge line is open.
- 5) Turn pump on and check amperage,voltage and pump output. If pump runs and sump liquid does not pump down, stop pump and close discharge gate valve. If on guide rail system lift pump until sealing flange is open to vent off trapped air. Lower pump, open discharge valve, start pump again.
- 6) Level control should be set so that pump turns off when level is at least 2 inches above inlet of pump suction and turns on when level is minimum 6 inches above motor.
- 7) The VN non-clog comes with thermal overload protection that shuts the motor off when it over heats because of low voltage, trash in the pump or other problems. Normally, motor cools in 10 minutes and restarts automatically.

Disassembly of Pump

Disassembly

Before starting contact a Webtrol sales representative. When disassembling pump, have a piece of cardboard or wooden board ready to place the different parts on as you work. Do not pile parts on top of each other. They should be laid out neatly in rows.

Warning: Let pump cool for at least 20 minutes before attempting to service. Motor may be extremely hot. Personal injury may result. Always disconnect the electrical supply before attempting to install, service, or perform any maintenance. If the power source is out of sight, lock and tag in the open (off) position to prevent unexpected power applications. Disconnect electrical cord from power supply. Failure to do so can result in fatal electrical shock. Only qualified electrician should repair this unit. Improper repair could result in fatal electrical shock.

Maintenance

Preventive annual inspections

- 1) Sewage series pump should be checked yearly for debris and/or build up which might interfere with "ON" or "OFF" position of variable level float switches.
- 2) Check pressure, output, voltage, current and other specifications. Unusual readings may indicate a problem. Refer to trouble shooting and correct as soon as possible.
- 3) Check the mechanical seal every six months. If you notice water mixed with oil or cloudy texture of the oil, these may be the indicator of a defective mechanical seal. To prolong the life of mechanical seal is recommended to replace oil in mechanical seal chamber once a year.
- 4) Conduct an overhaul of the pump every 3-5 years. These overhauls will prevent the possibility of future trouble.

Pump Assembly

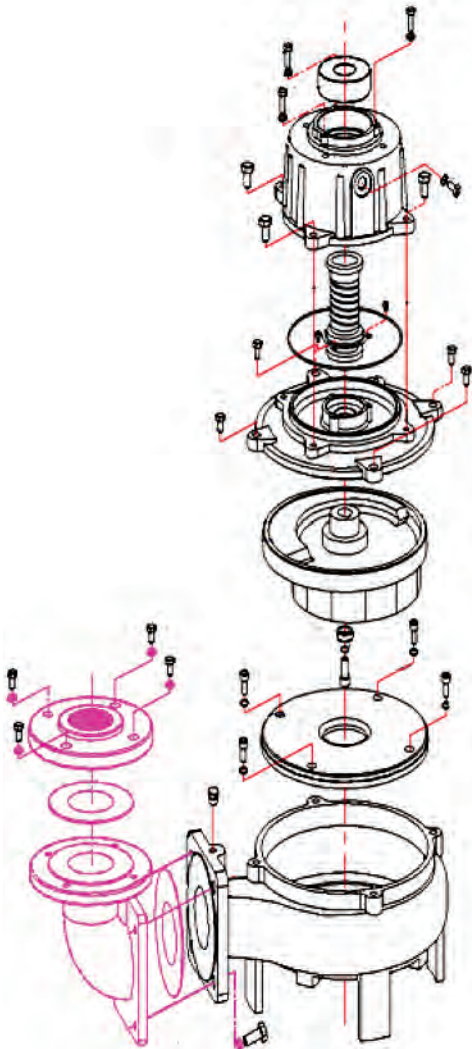

System Trouble Shooting

Does not start. Starts, but immediately stops.

Possible Cause Of Trouble	Corrective Action
Power failure	Contact electric power company and devise counter-measures
Large discrepancy between power source and voltage	Contact electric power company and devise counter-measures
Significant drop in voltage	Contact electric power company and devise counter-measures
Motor phase malfunction	Inspect electric circuit
Electric circuit connection faulty	Correct wiring
Faulty connection of control circuit	Inspect connections and magnetic switch
Fuse blown	Replace with correct type of fuse
Faulty magnetic switch	Replace with correct one
Water is not at level indicated by float	Raise water level
Float is not in appropriate level	Adjust the position of float
Float defective	Repair or replace
Short circuit breaker is functioning	Repair location of short circuit
Foreign matter clogging pump	Remove foreign matter
Motor burned out	Repair or replace
Motor bearing broken	Repair or replace

Operates, but stops after a while.

Possible Cause Of Trouble	Corrective Action
Prolonged dry operation has activated motor protector and caused pump to stop	Raise stop water level
High liquid temperature has activated motor protector and caused pump to stop	Lower liquid temperature
Reverse rotation	Correct rotation (see Operation)

Does not pump. Inadequate volume.

Possible Cause Of Trouble	Corrective Action
Significant drop in voltage	Contact electric power company and devise counter-measures
Operating a 60 Hz pump on 50Hz	Check nameplate
Discharge head is high	Recalculate and adjust
Large piping loss	Recalculate and adjust
Low operating water level causes air suction	Raise water level or lower pump
Leaking from discharge piping	Inspect, repair
Clogging of discharge piping	Remove foreign matter
Foreign matter in suction inlet	Remove foreign matter
Foreign matter clogging pump	Remove foreign matter
Worn impeller	Replace impeller

Over current

Possible Cause Of Trouble	Corrective Action
Unbalanced current and voltage	Contact electric power company and devise counter-measure
Significant voltage drop	Contact electric power company and devise counter-measure
Motor phase malfunction	Inspect connections and magnetic switch
Reverse rotation	Correct rotation (see Operation)
Low head. Excessive volume of water	Replace pump with low head pump
Foreign matter clogging pump	Remove foreign matter
Motor bearing is worn or damaged	Replace bearing

Pump vibrates; excessive operating noise.

Possible Cause Of Trouble	Corrective Action
Motor bearing is worn or damaged/reverse rotation	Correct rotation
Pump clogged with foreign matter	Disassemble and remove foreign matter
Piping resonates	Improve piping
Gate valve is closed to far	Open gate valve

Seal leaks

Possible Cause Of Trouble	Corrective Action
Worn Seal	Replace seal
Pump head loose on motor	Ensure proper assembly and no obstruction , tighten bolt Improve piping

Owners Information

Name Of Dealer: _____ Phone: _____

Address: _____

Installed By: _____ Date: _____

Pump Model No: _____ HP: _____ Date Code: _____

Power Supply: _____ Volts: _____ Service Factor Amps: _____

Cable Size: _____ AWG: _____ Ft.: _____

Riser Pipe Size: _____ Material: _____ Length (Inches): _____

Septic Tank Size Gallons: _____

Float Height (Inches): Pump _____ On, _____ Off, Timer Override (Inches): _____ On, _____ Off

Low Level Cutoff (Inches): _____ Redundant Off (Inches): _____

Timer Settings (Minutes/Hours): On _____ Off _____ High Level Alarm (Inches): _____

Note! Float location to be measured from the bottom of the tank.

Other Information: _____

Thank You for Purchasing an VN Series Non-Clog Wastewater Pump

We at Webtrol are constantly working on new products to make your job easier, while making your systems more efficient, reliable and affordable.

Your opinion means a lot to us, so please let us know what you think about our VN Series Non-Clog Wastewater Pump.



There when you need us most

8417 New Hampshire Ave. | St. Louis, MO 63123

Phone: (314) 631-9200 **Fax:** (314) 631-3738 **E-mail:** comments@webtrol.com