



There when you need us most

MVGS SERIES GRINDER PUMPS

Stainless Steel/Cast Iron Grinder Pumps



The MVGS Series grinder pumps provide you with reliable solutions for a variety of residential and commercial applications.

The quality and performance you expect, along with industry best lead times and personalized service, only from Webtrol!

**2 Year
Warranty**



Features and Benefits

- Constructed from 304 SS and Cast Iron
- Recessed vortex cast iron impeller
- Hardened anti-wear grinding ring and cutter
- Double mechanical seals for better motor protection
- 3450 RPM, 2 pole motor
- Oil filled continuous duty motor
- 20' power cord
- Potted epoxy cord seal
- Built-in overload protection
- Available with 1.25" flange connection
- Available in prepackaged basin

Performance

HP Range: 1 and 2 HP, 60Hz.
 Capacities to 40 GPM
 Heads to 100'
 Temperatures to 104° F

Typical Services

- Residential Wastewater
- Commercial Wastewater

Model	HP	Volt	Discharge	Cord Length	Dimensions (L x W x H)	Weight
MVGS10CE	1	230	1.25"	20'	16" x 12.5" x 28.5"	88 lbs.
MVGS20CE	2	230	1.25"	20'	16" x 12.5" x 28.5"	88 lbs.



There when you need us most

MVGS SERIES GRINDER PUMPS

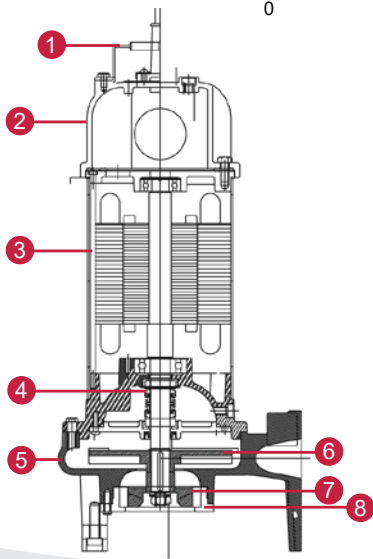
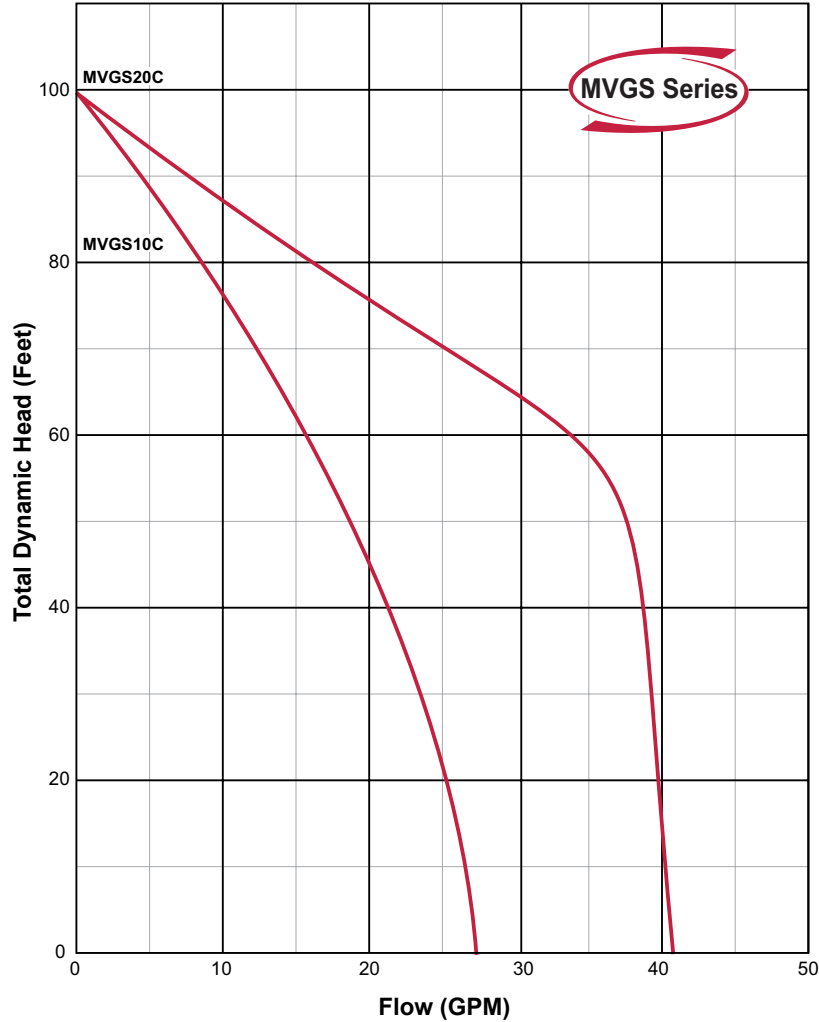

CONSTRUCTION MATERIALS		
Number	Part	Material
1	Handle	304 SS
2	Top Cover	Cast Iron
3	Motor Housing	304 SS
4	Double Mechanical Seal	Ceramic Carbon & Silicon Carbide
5	Pump Volute	Cast Iron
6	Impeller	Cast Iron
7	Cutter	Chrome Steel
8	Cutter Ring	Chrome Steel