



There when you need us most

VN SERIES SUBMERSIBLE PUMPS

Non-Clog Wastewater Pumps

VN Series

VN Series single channel non-clog submersible pumps are designed for the most demanding commercial and industrial applications.

The quality and performance you expect, along with industry best lead times and personalized service, only from Webtrol!



Features and Benefits

- All cast iron construction
- 3" solids handling
- Single channel, ductile iron impeller
- Double mechanical seal for better motor protection
- 1750 RPM (4 pole motor)
- Oil filled continuous duty motor
- 20' power cord
- Potted epoxy cord seal
- Available with 4" flange connection
- Available in prepackaged basins

Performance

HP Range: 5 - 10 HP, 60Hz.
 Capacities to 800 GPM
 Heads to 76'
 Temperatures to 104° F

Typical Services

- Municipal Wastewater Lift Stations
- Wastewater Treatment Facilities
- Commercial/Industrial Wastewater Applications

Model	HP	Volt	Phase	Amps	Discharge	Cord Length	Dimensions (L x W x H)	Weight
VN50C49	5	230	3	12.0	4"	20'	25.7" x 15.8" x 32.5"	265 lbs.
VN50D49	5	460	3	6.0	4"	20'	25.7" x 15.8" x 32.5"	265 lbs.
VN75C62	7.5	230	3	18.0	4"	20'	25.7" x 15.8" x 32.5"	267 lbs.
VN75D62	7.5	460	3	9.0	4"	20'	25.7" x 15.8" x 32.5"	267 lbs.
VN100C76	10	230	3	23.0	4"	20'	25.7" x 15.8" x 32.5"	276 lbs.
VN100D76	10	460	3	11.5	4"	20'	25.7" x 15.8" x 32.5"	276 lbs.

VN SERIES SUBMERSIBLE WASTEWATER PUMPS

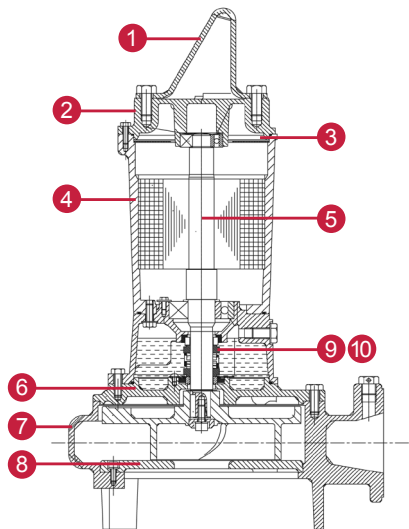
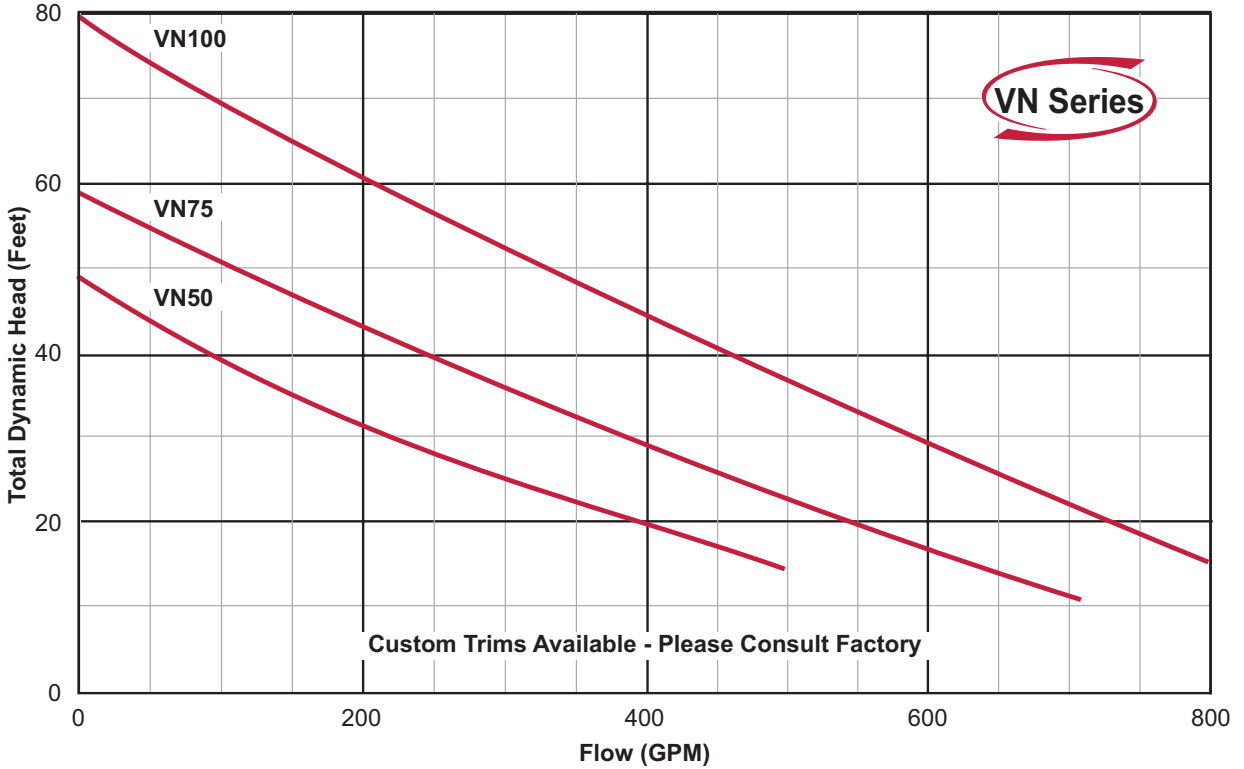

CONSTRUCTION MATERIALS		
Number	Part	Material
1	Handle	Steel Plated
2	Top Cover	Cast Iron
3	O-Ring	NBR
4	Motor Housing	Cast Iron
5	Motor Shaft	410 SS
6	Seal Plate	Cast Iron
7	Pump Casing	Cast Iron
8	Bottom Plate	Cast Iron
9	Mechanical Seal (Primary)	Silicon Carbide/Silicon Carbide
10	Mechanical Seal (Secondary)	Carbon/Ceramic