



There when you need us most

ACE Series

Cast Iron End Suction Centrifugal Pump

Installation & Operating Manual



Congratulations on Your Choice in Purchasing this Webtrol Pump!

Its Quality is unsurpassed in material and workmanship and has been factory tested.
If properly installed, it will give many years of trouble free service.

SAFETY WARNINGS



BEFORE OPERATING OR INSTALLING THIS PUMP, READ THIS MANUAL AND FOLLOW ALL SAFETY RULES AND OPERATING INSTRUCTIONS.

SAFETY CAREFULLY READ THESE SAFETY MESSAGES IN THIS MANUAL AND ON PUMP.

CAUTION

- **DO NOT OPERATE THIS PUMP DRY!**
- Review instructions before operating.

WARNING - ELECTRICAL PRECAUTIONS

All wiring, electrical connections, and system grounding must comply with the National Electrical Code (NEC) and with any local codes and ordinances. Employ a licensed electrician. For non-thermally protected motors use with approved motor control that matches motor input in full load amperes with overload element(s) selected or adjusted in accordance with control instructions.

Adhere to the guidelines of national, state and local plumbing codes when installing this product. Check with the appropriate agencies or water system professional for additional information.

WARNING - RISK OF ELECTRICAL SHOCK

- Have an electrician provide electrical power to motor.
- All wiring and electrical connections should comply with the National Electrical Code (NEC) and with local codes and ordinances.
- A ground fault interrupter (GFI) protected circuit is recommended for use with any electrical device operating near water.

APPLICATION

These pumps are suitable for installations where the vertical distance from the pump to the water level does not exceed 25 ft. (7.5m), including drawdown. In all installations friction losses in the piping must be taken into consideration.

PERFORMANCE

HP	Total Head in Feet										
	20	30	40	50	60	70	80	100	120	140	150
	Capacities in U.S. GPM										
1/2	46	40	37	30	22	12	-	-	-	-	-
3/4	56	52	47	42	36	29	19	-	-	-	-
1	61	57	54	49	44	39	32	12	-	-	-
1-1/2	69	67	63	59	54	49	43	24	-	-	-
2	90	89	87	83	79	72	63	42	11	-	-
3	140	140	132	124	116	107	98	78	38	-	-
5	152	152	152	152	152	150	141	120	96	67	40

INSTALLATION

a) PUMP LOCATION: The pump should be installed in a clean, dry and ventilated location. Provisions should be accommodated for adequate drainage, room for servicing, and protection from freezing temperatures. The unit should be bolted down evenly on a good foundation, preferably concrete, to prevent the development of unnecessary stresses. Locating the pump as close as possible to the source of water supply reduces the friction losses in the suction pipe and provides maximum capacities.

b) SUCTION LINE: Before installing the suction line, check the pump rotation as outlined below. It is recommended that only new, clean pipe or suction hose be used and the size be the same as that of the pump suction tapping. If the pump is installed any appreciable distance away from the source of water supply, the suction pipe should be increased by one size. The suction pipe should never allow a downward water flow in its connections from water supply to the pump (see Fig. 1). A foot valve must be connected to the bottom of the suction line and should be clear of any possible obstructions.

These valves are available from your pump supplier. It must be ensured that the foot valve remains well submerged at all times. If large debris is present at the suction point, install a filtration device to prevent the debris from entering the pump. Thread compound should be used on all pipe joints. All connections should

be thoroughly tightened. A leak in the suction line may prevent a complete prime and will reduce pump operating performance. Figure 2 shows a typical pump installation.

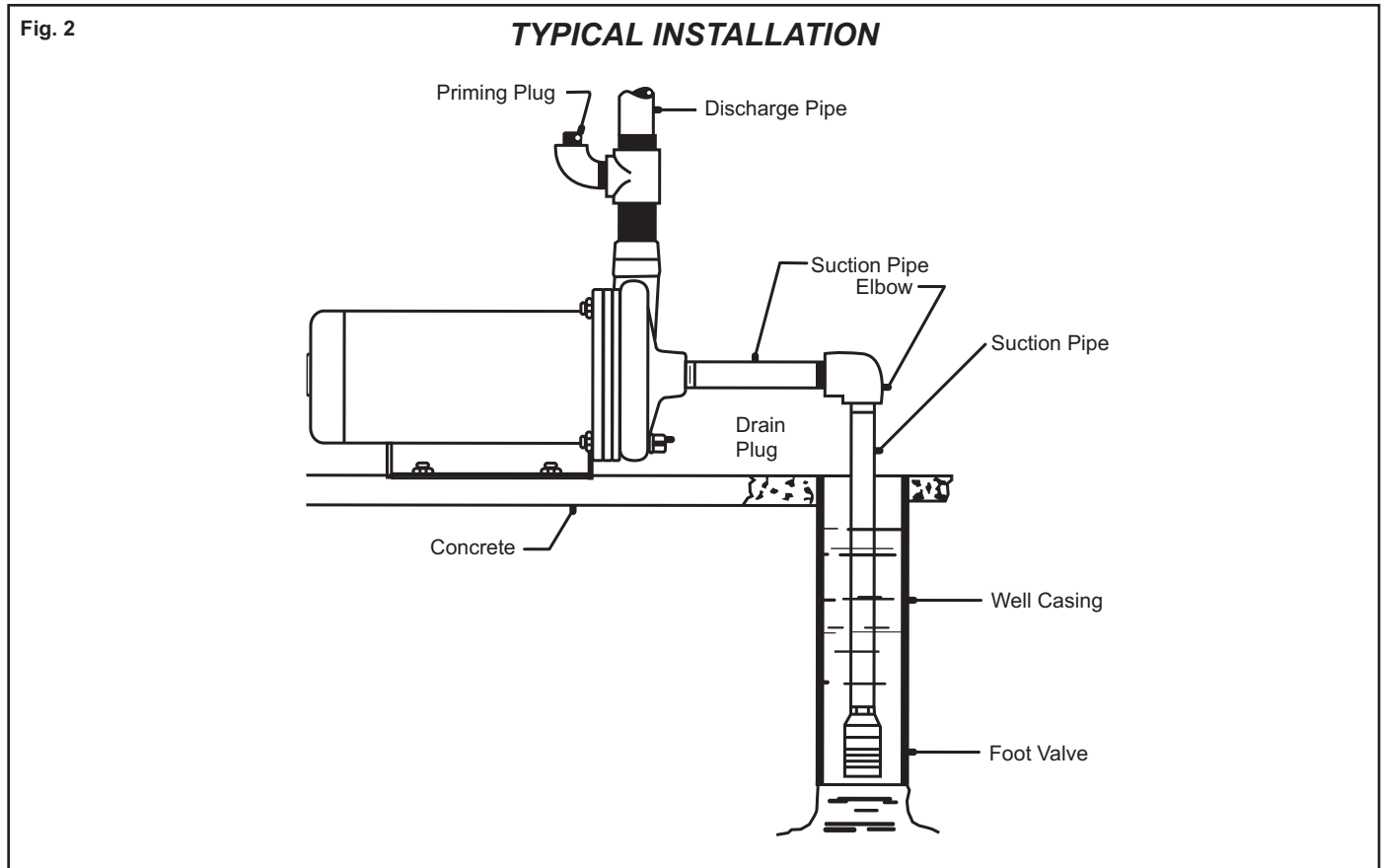
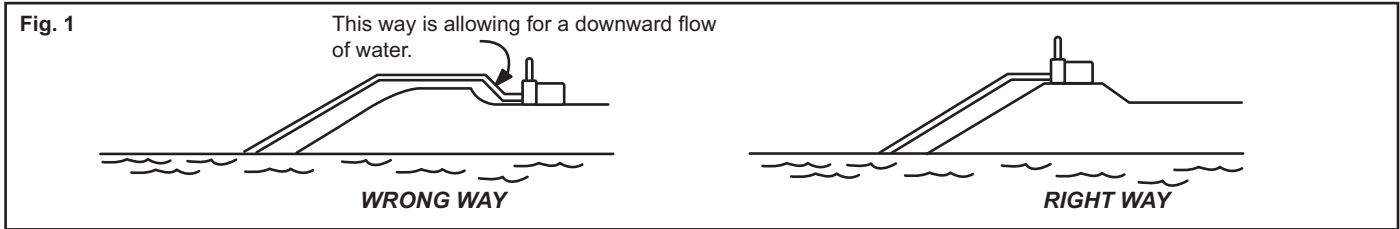

c) DISCHARGE LINE: A priming plug should be installed as shown in Figure 2. Long hose or pipe lengths add resistance to water flow which therefore reduces pumping capacity. Use standard approved pipe or hose suitable for the pumping pressures which develop and use lengths only as necessary to reach the discharge point. Avoid using nozzles or reducing fittings on the discharge line if they are not required in your application. The discharge pipe or hose should be at least as large as the discharge thread opening on the pump casing. If long line lengths are required, increase pipe/hose size accordingly. Avoid unnecessary bends in lines. Proper installation will enable efficient service from your pump.

d) WIRING: All wiring, electrical connections, and system grounding must comply with the National Electrical Code (NEC) and with any local codes and ordinances. Employ a licensed electrician. It is recommended that a separate circuit be led from the distribution panel to the pump unit. A proper fused disconnect switch is to be installed in the line, making sure that the correct gauge of cable is used to carry the load. Very long leads will require a larger cable. For all 3-Phase motors a separate manual thermal overload switch or a magnetic starter having the proper size heater elements must be installed. An electrician should be employed to do the wiring. After wiring is complete check the impeller rotation by switching the motor on for one second only.

OPERATION - PRIMING THE PUMP

⚠ WARNING: DO NOT RUN THE PUMP BEFORE PRIMING IT, SINCE THE SEAL AND IMPELLER COULD BE PERMANENTLY DAMAGED.

- a) **PRIMING:** These pumps are not self-priming. For best priming, fill the pump casing and the suction line full with water.
To prime the casing – Remove the priming plug and the drain plug (See Figure 2). Pour clean water into the priming hole. Replace the drain plug. Fill the pump casing full. Rotate the motor shaft manually from the back of the motor to release internal air pockets inside the casing. Refill, if necessary at the priming hole. Replace the priming plug.
- b) **STARTUP:** Dry operation may damage the water lubricated seal inside the pump. If the pump does not deliver water within seconds after startup, stop the motor and repeat the priming operation. Several starting attempts may be necessary to expel all of the air from the pump and suction lines.
- c) **CONTINUOUS OPERATION:** Check the pump periodically for loose or rubbing parts. Service the pump immediately if any unusual noise, leaks or vibrations develop.
- d) **DRAINING:** Should the pump be subject to freezing temperatures, it will be necessary to completely drain the fluid from the pump and lines. To drain the pump casing, remove the drain plug and the priming plug. Disconnect the suction line at a connection close to the pump casing and allow the water to drain from the suction line. Operate the pump for a few seconds only to clear water from the impeller. Replace the suction line carefully cleaning the threads and applying fresh thread compound.
- e) **ROTATION:** The arrow on the front of the pump casing indicates the correct rotation of the impeller during operation. Wire the motor as described above. If it is not turning in the proper direction refer to the motor wiring instructions.

MAINTENANCE

⚠ WARNING - ELECTRICAL PRECAUTIONS

All wiring, electrical connections, and system grounding must comply with the National Electrical Code (NEC) and with any local codes and ordinances. Employ a licensed electrician.

⚠ WARNING - RISK OF ELECTRICAL SHOCK

Before servicing motor operated equipment, shut off the power at the main electrical panel and disconnect the power supply from the motor and the accessories. Use safe working practices during servicing of equipment.

- a) **LUBRICATION:** The pump itself does not need lubrication. Refer to instructions provided with the motor for motor lubrication and maintenance.
- b) **REPLACEMENT OF SEAL:** If available, refer to the repair parts list illustration showing the relative location and names of all components to assist you while following these instructions.

Disassembly:

- 1) Disconnect piping and wiring.
- 2) Remove the four nuts to dismount the pump casing from the motor housing.
- 3) Remove motor's end cover (if required).
- 4) Secure motor's shaft end with screwdriver and remove impeller by turning it counter-clockwise.
- 5) Remove the spring seal from the shaft and slide the seal plate off.
- 6) Remove the ceramic seat and its rubber housing from the seal plate.

Reassembly:

- 1) Clean all parts thoroughly. Inspect for damage or wear.
- 2) Liquid soap the rubber only of the stationary seal seat. Use clean thumbs only to press seat into seal plate. Make sure that seat is fully seated and wipe clean.
- 3) Slide the seal plate onto the shaft being careful not to damage the ceramic seat.
- 4) Lightly soap the internal rubber ring of the rotary spring seal assembly and slip in onto the motor shaft with the shiny side of the ring towards the ceramic seat.
- 5) Reassemble the impeller onto the shaft. Tighten "hand tight" only.
- 6) Place a new gasket onto the seal plate.
- 7) Place the casing into position and attach the motor using new spring washers and existing bolts. Use thread locking/sealing compound on casing to prevent leaks. Do not over-tighten the bolts.
- 8) Check that the impeller is not rubbing with the pump casing by rotating the motor shaft by hand.
- 9) Replace motor's end cover (if required).
- 10) Reconnect piping and wiring.
- 11) Reprime pump system.

PRECAUTIONS

- a) Whenever reassembly of pump is involved, check to see that the impeller rotates freely within the casing.
- b) Never remove the water flinger from the motor shaft unless replacing a damaged flinger. Be sure the motor has a flinger installed at all times.

TROUBLESHOOTING GUIDE

- a) Pump fails to deliver water:**
- 1) Pump is not properly primed.
 - 2) Impeller does not rotate freely within the casing.
 - 3) Suction lift is too great.
 - 4) Foot valve is either not submerged, buried in mud, or is blocked.
 - 5) Suction line is completely choked.
- b) Pump delivers water but not at rated capacity:**
- 1) Leaks in suction or discharge line.
 - 2) Foot valve, suction line or impeller are partially plugged.
 - 3) Suction lift is greater than recommended.
 - 4) Improper impeller rotation.
- c) Pump loses prime:**
- 1) Air leaks in suction line or foot valve.
 - 2) Well drawdown too great.
 - 3) Faulty foot valve.
- d) Motor will not start:**
- 1) No power due to blown fuses, open switches or loose connections.

REPLACEMENT PARTS

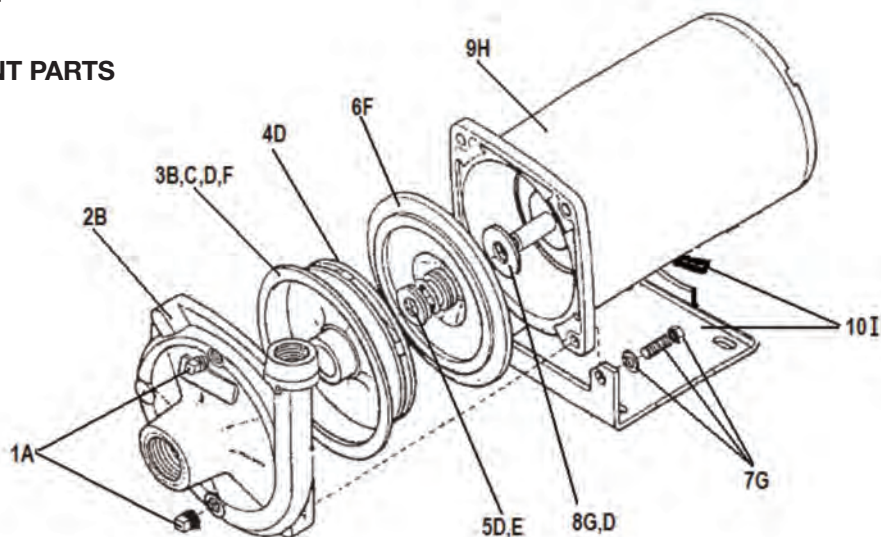

Number	Description	Kit Grouping Identifier	Repair Part Order Codes by Model Number				
			1/2 hp	3/4 hp	1 hp	1-1/2 hp	2 hp
1	Plugs Kit	A	305446953				
2	Casing	B	305446922				305446923
3	Gasket	C	305446932				305446933
		F	305446929				305446930
		D	305446924	305446925	305446926	305446927	305446928
4	Impeller	D	305446924	305446925	305446926	305446927	305446928
5	Mechanical seal	E	106196218				
6	Seal Plate	F	305446929				305446930
7	Fastener Kit*	G	305446931				
8	Flinger	D	305446924	305446925	305446926	305446927	305446928
9	Motor	H	305446955	305446956	305446957	305446958	305446959
10	Base Assembly	I	305446960				

†Items with like identifiers are sold/packaged together

*Fastener kits (7G) is a complete set of the hardware used to assemble the pump. As a convenience kit B, D & F contain the fasteners needed for the reassembly of its components.

Page intentionally left blank

Thank You for Purchasing an ACE Series Centrifugal Pump

We at Webtrol are constantly working on new products to make your job easier, while making your systems more efficient, reliable and affordable.

Your opinion means a lot to us, so please let us know what you think about our ACE Series Centrifugal Pump.



There when you need us most

8417 New Hampshire Ave. | St. Louis, MO 63123

Phone: (314) 631-9200 **Fax:** (314) 631-3738 **E-mail:** comments@webtrol.com